

Stands

Comparison measuring instruments which ensure high quality, high accuracy and reliability.

SERIES 519 — Transfer Stands

- Transfer Stands are designed for comparison measurements of size using a dial indicator or Digimatic Indicator.



519-109-10
(with a serrated anvil)

SPECIFICATIONS

Metric			
Order No.	Clamping range on column (mm)	Micromotion adjustment range (mm)	Stem hole (mm)
519-109-10	0 to 320	1	ø9.53, ø8 with Bush

Note 1: Perpendicularity of the stem hole to the anvil is better than 0.4 mm/100 mm.

Note 2: Take note that when mounting high-accuracy Linear Gages (with resolution of 0.1 µm or better) to these stands, accuracy may be affected depending on the perpendicularity of the mounting hole to the top surface of the anvil (cosine effect).

Note 3: Compact dial indicators (bezel ø31, ø36) are not suitable for use with these stands.

DIMENSIONS

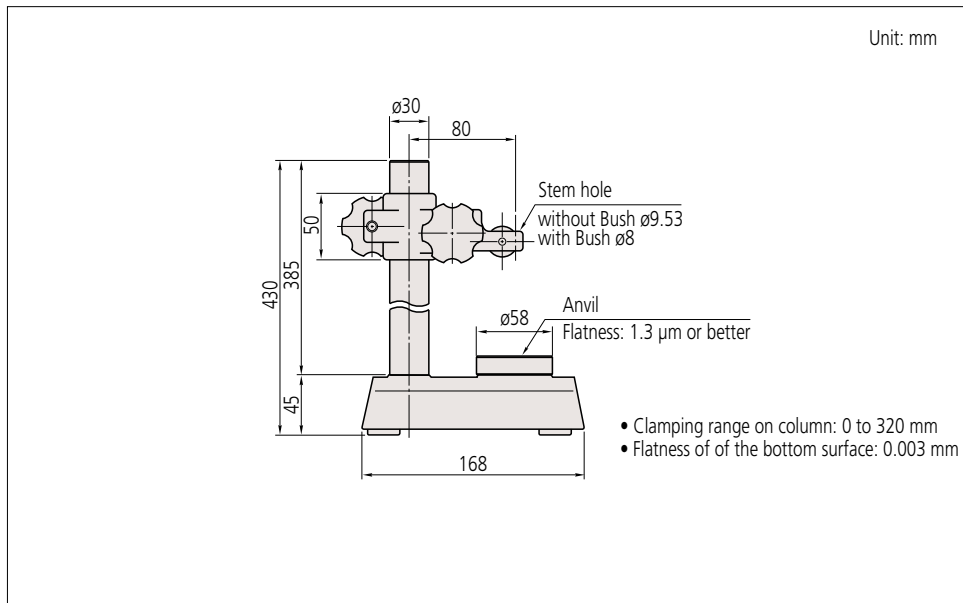

Accessories

101462: Hardened steel serrated anvil (standard accessory)



101461: Hardened steel non-serrated anvil (optional)

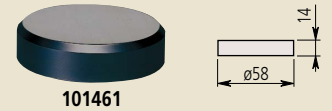

101463: Hardened steel domed anvil (optional)

