

Operating Method

- Pulling the lever forwards moves the platen upwards and the instrument goes into measurement mode.
- The V-attachment (optional) aids positioning the workpiece on the platen and is useful when measuring a large number of the same size of workpiece.

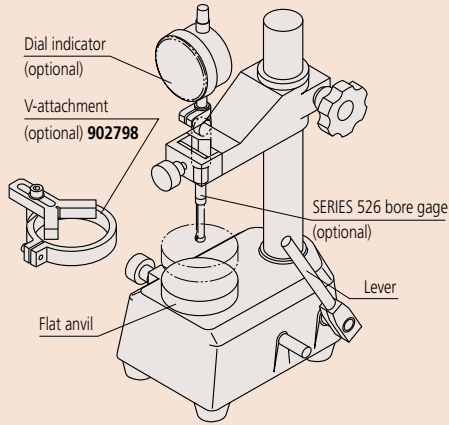

Optional Accessory

- V-attachment: 902798

Bore Gage Stand SERIES 215

- Optimal for efficient measurement of multiple small holes with a bore gage. (SERIES 526)



215-120-10

SPECIFICATIONS

Order No.	Measuring table displacement (mm)	Measuring table
215-120-10	38	Anvil (ø60 mm)

DIMENSIONS

