

## Paper Thickness Micrometers SERIES 169 — Non-Rotating Spindle Type



- For paper thickness measurement.
- Non-rotating spindle.
- Anvil diameter 14.3 mm (without recess)
- Equipped with Ratchet Stop for constant measuring force. (8.02±0.8 N)



169-101-10

### Anvil Dimensions

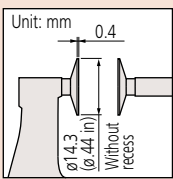

( ) : Inch model

### Standard Accessories

Spanner (301336), 1 pc.

### SPECIFICATIONS

Metric					
Order No.	Range (mm)	Graduation (mm)	Maximum permissible error $J_{MPE}$ ( $\mu\text{m}$ )	Flatness ( $\mu\text{m}$ )	Parallelism ( $\mu\text{m}$ )
169-101-10	0 - 25	0.01	±4	1	3

Inch					
Order No.	Range (in)	Graduation (in)	Maximum permissible error $J_{MPE}$ (in)	Flatness (in)	Parallelism (in)
169-103-10	0 - 1	0.001	±0.0002	0.00004	0.00015

### DIMENSIONS

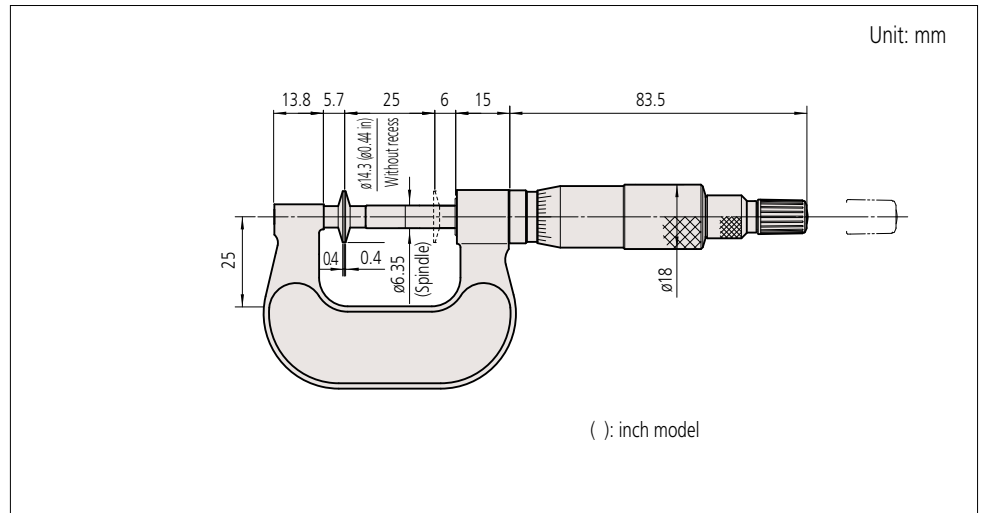

( ) : inch model