

Micrometer Head

The origin of Mitutoyo's trustworthy brand of small tool instruments

Micrometer Heads

SERIES 148 — Fine Spindle Feed of 0.25 mm/rev

- Micrometer head with 0.25 mm spindle pitch is convenient for fine-feed and fine-positioning applications.

DIMENSIONS

Plain Stem

Unit: mm

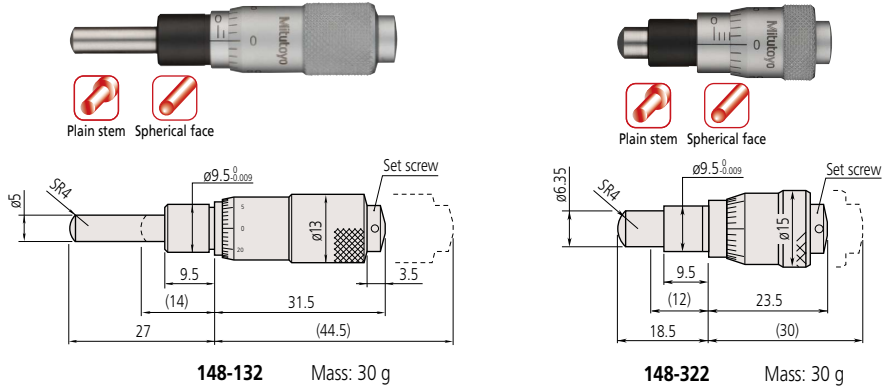

Stem Locknut

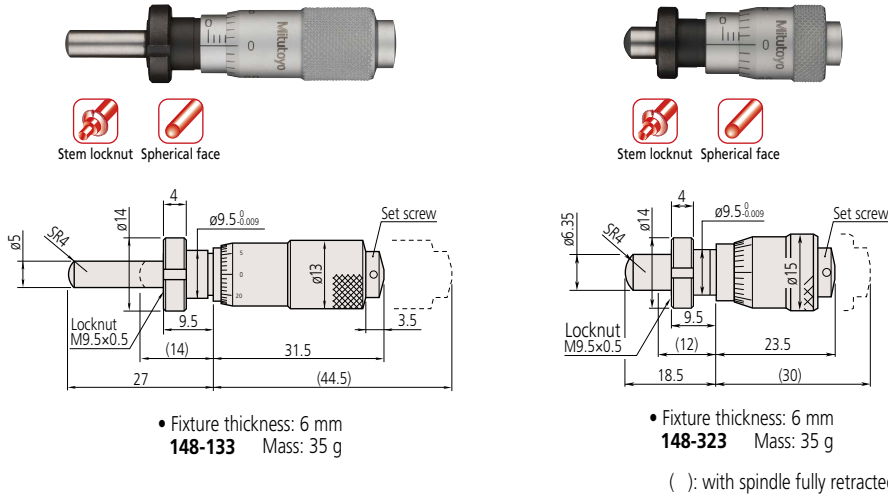

Technical Data

- Measuring face
Material: Alloy tool steel
Hardness: 60 HRC or more
Lapped
- Scale finishing:
Satin-chrome plated

SPECIFICATIONS

Metric

Order No.	Stroke (mm)	Graduation (mm)	Stem dia. (mm)	Stem	Spindle end	Spindle pitch (mm)	Maximum permissible error J_{MPE} (μm)
148-132	13	0.01	9.5	Plain	Spherical (SR4)	0.25	± 2
148-133				W/clamp nut			
148-322	6.5	0.01	9.5	Plain	Spherical (SR4)	0.25	± 2
148-323				W/clamp nut			