

## MECHANICAL TYPE



VPS-301



VPS-302



CERAMIC TYPE VPS-301C

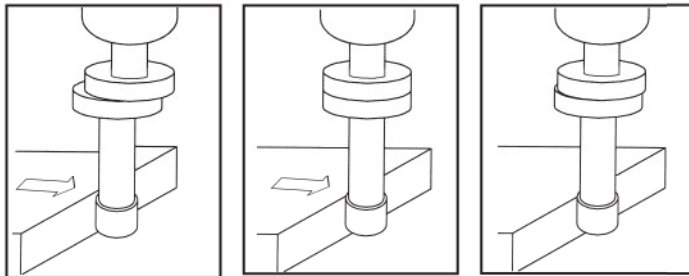
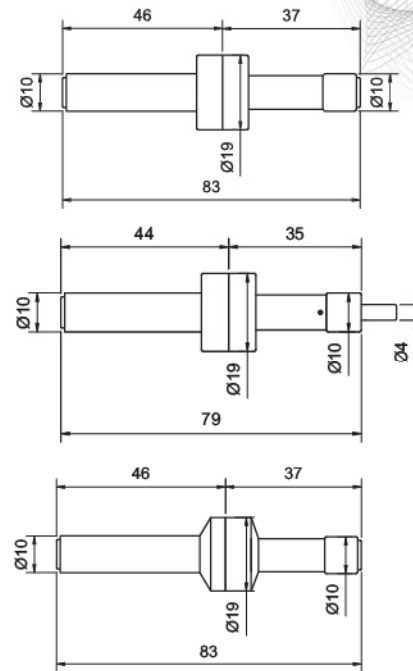

Spindle runs about 500rpm. move spindle closed to measuring surface.

When measuring probe touches workpiece, it looks in one part.

When the probe and shank are in alignment, probe will slide out of rotating center. Now, the center spindle is located 5mm away from measuring surface

- Accuracy of zero point to point is within 0.003mm
- R.P.M. within 450-600.
- Max. flange can be clear your sight sense.
- MIN.(4mm) can be test mini hole for your workpiece.

ORDER NO.	MATERIAL	HARDNESS	WEIGHT (kg)	CODE NO.
VPS-301	ALLOY STEEL	HRC 56°	0.06	3402-100
VPS-302			0.05	3402-101
VPS-301S	STAINLESS	HRC 60°	0.06	3402-102
VPS-302S			0.06	3402-103
VPS-301C	CERAMIC	HRC 60°	0.06	3402-104

# Centering Indicator

ORDER NO.VCI-170 CODE NO.3402-130

- RPM Within 800.
- Use for Internal or External.
- Use for Vertical or Horizontal.
- While Spindle Rotates, With Stop bar for Fixing The Head The Centering Indicator Always faces the operator.

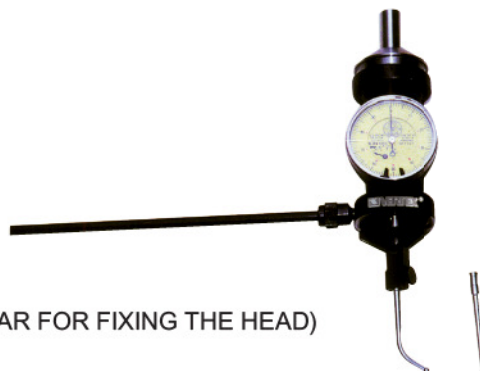

(WITH STOP BAR FOR FIXING THE HEAD)

Shank	$\varnothing 10$	m/m
Length	170	m/m
Internal	$\varnothing 4 \sim \varnothing 108$	m/m
External	$\varnothing 0 \sim \varnothing 108$	m/m
Min. Indicator	0.01	m/m
Indicator Range	0~6	m/m
Weight	0.8	kgs