



HARDY

3001#

CROSS SLIDING TABLE

精密十字工作台

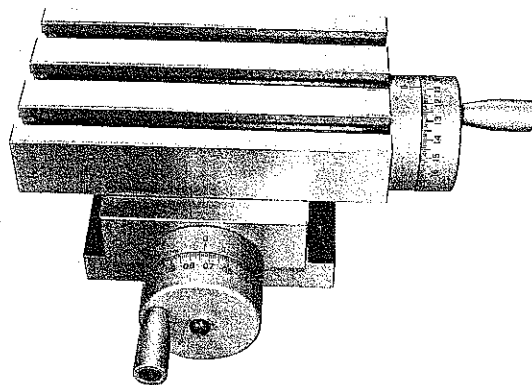

CST-100

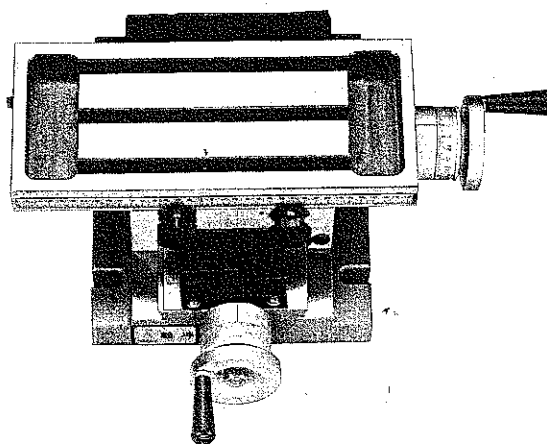

CST-150,200,250,250A

1. Material: FC30, high quality.
2. Suitable for drilling machine or precise repeat positioning.
3. Parallel and perpendicular capability within 0.03 m/m

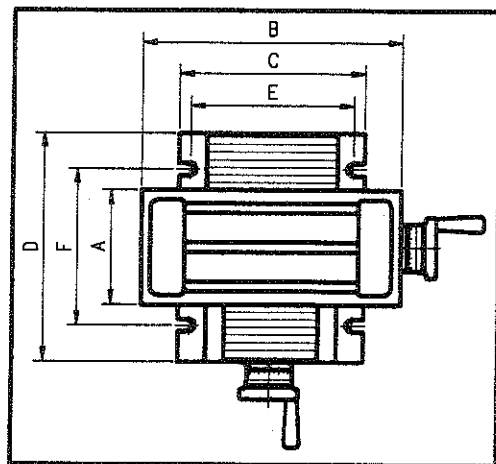

MODEL	A	B	C	D	E	F	TRAVEL	T-SLOT	HEIGHT	DIAL	PACKING L×W×H m/m	WEIGHT
CST-100	100	185	130	100	115	50	50×80	3/8"	100	2/0.01 m/m	290×240×140	12/13.5kg
CST-150	150	350	250	300	220	205	150×175	3/8"	130	4/0.02 m/m	510×450×240	31/37.5kg
CST-200	200	500	300	400	250	290	200×250	3/8"	160	4/0.02 m/m	670×560×280	60/73kg
CST-250	250	600	400	500	340	430	250×300	1/2"	210	4/0.02 m/m	790×680×310	119/141kg
CST-250A	250	800	400	500	340	430	250×500	1/2"	210	4/0.02 m/m	1000×680×310	139/165kg