



276p



276p



277p



277p



277p



277p



277p



277p



278p



278p



278p



278p

# OTHERS



279p



279p



279p



279p



280p



280p



281p



281p



281p



282p



282p



282p



282p



282p



282p



282p

SURVEYORS  
WHEEL

COUNTER

DRILL  
CASE

TOOLING

ELECTRIC  
TOOLS

WORKING  
TOOLS

SUCTION  
LIFTER



# ROAD COUNTER

Measure distance by simply rolling! Equipped with a convenient stand to support in an upright position

- Maximum measurement distance: 9999.9m
- Minimum display: 10cm



With carrying bag

- USE**
  - Distance measurement in road construction or on building site, land measurement, or ground maintenance.
- FEATURES**
  - Distance measurement by simply rolling
  - Equipped with a convenient stand to hold in an upright position.
  - With carrying bag

Order No.	Model No.	Minimum Display	Maximum Measurement Distance	Counter Display	Measurement Error	Weight
111226	RM-4	10cm	9999.9m	First digit on right : 10cm dist. display 4 digits on left: meters display	within 0.15%	570g



# ROAD COUNTER

Measure distance by simply rolling! Equipped with a convenient stand to support in an upright position

- Maximum measurement distance: 999.99m / Minimum display: 1cm



With carrying bag

- USE**
  - Distance measurement in road construction or on building site, land measurement, or ground maintenance.
- FEATURES**
  - Distance measurement by simply rolling
  - Double wheel for a stable measurement
  - With carrying bag

Order No.	Model No.	Minimum Display	Maximum Measurement Distance	Counter Display	Measurement Error	Weight
111227	RM-3MW	1cm	999.99m	2 digits on right: cm display 3 digits on left: meters display	within 0.15%	570g

**There is no doubt for the correct count!**

- **USE** • For checking product quantity, traffic volume, headcount or other counting tasks.
- **MATERIAL** • Steel  
• Plastic (C-4PC)
- **FEATURES**
  - 1 count per push. Various type available for every application.
  - 4 digit counter
- **POWER (DC-4WS)**
  - 2pcs of LR44 (for testing)



Order No.	Model No.	TYPE	Weight
151740	C-4B	Stand type	77g
151741	C-4H	hand-held	53g
151742	C-4PC	Plastic	33g
151744	DC-4WS	Digital	45g

**SAFETY CAP FOR ENDMILLS**

- **USE** • Protects tips of endmills
- **FEATURES**
  - Polypropylene
  - Easy to distinguish endmills with clear case
  - Suitable for protecting tip of endmills kept on tooling rack
  - Designed to prevent slipping out



Order No.	Model No.	Shaft Dia. (mm)	Length (mm)	Protection Length (mm)	1 Set contains	Weight
111130	AMS-06	6	45	40	100 pcs	60g
111131	AMS-08	8	45	40	100 pcs	80g
111132	AMS-10	10	77	70	100 pcs	180g
111133	AMS-12	12	77	70	100 pcs	210g
111134	AMS-16	16	122	110	50 pcs	250g
111135	AMS-20	20	122	111	50 pcs	350g
111136	AMS-25	25	170	117	50 pcs	380g
111137	AMS-32	32	170	150	20 pcs	400g
111138	AMS-42	42	215	190	20 pcs	700g
111139	AMS-55	55	215	190	20 pcs	950g

**DRILL BIT CASE**



- **USE** • Arranging drill bits
- **FEATURES**
  - Plastic
  - Arranging drill bits for easy access with size marking
  - Rotary type

storage size

R-113	1.0~10.0 (0.1 step)	1.0 ~9.8	1.1 9.9	1.2 10.0	1.3	91pcs	計100pcs
	Other size	10.5 12.0	10.9 12.5	11.0 12.9	11.5 13.0	9pcs	

Order No.	Model No.	Type	Dimension (mm)	Weight
013010	R-113	Rotary	Diameter×Height 180×82	300g

# STYLUS CENTER

**SR-10**

**SR-104**

**SR-104L**

**SR-102**

## DIMENSIONS

Units: mm

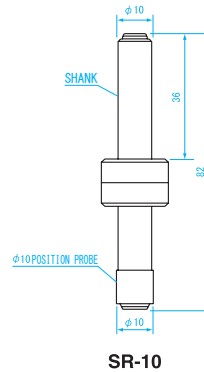
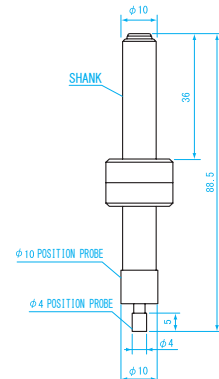
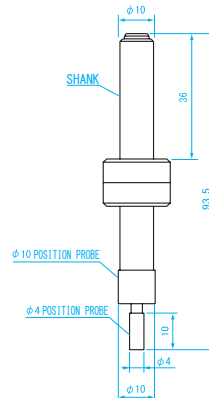
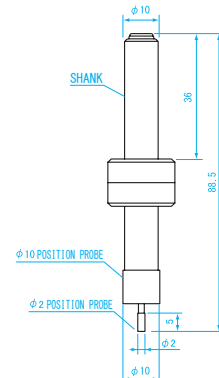
**SR-10**

**SR-104**

**SR-104L**  
(Long probe type)

**SR-102**  
(Thin probe type)

### USE

- High precision centering X and Y axis

### FEATURES

- High carbon chromium steel
- Position detection within  $\pm 2 \mu\text{m}$
- Working face is lapped finish
- General, NC milling machine, MC origin positioning, high accuracy positioning
- Position probe on workpiece edge

Order No.	Model No.	Probe (mm)	Shank Diameter (mm)	X-Z Repeatability	Operating Speed (rpm)	Weight
013310	SR-10	$\phi 10$	10	Within $\pm 2 \mu\text{m}$	450 ~ 600	55g
013314	SR-104	$\phi 4 \times 5 \cdot \phi 10$	10	Within $\pm 2 \mu\text{m}$	450 ~ 600	56g
013320	SR-104L	$\phi 4 \times 10 \cdot \phi 10$	10	Within $\pm 2 \mu\text{m}$	450 ~ 600	57g
013325	SR-102	$\phi 2 \times 5 \cdot \phi 10$	10	Within $\pm 2 \mu\text{m}$	450 ~ 600	56g

SURVEYORS WHEEL

COUNTER

DRILL CASE

TOOLING

ELECTRIC TOOLS

WORKING TOOLS

SUCTION LIFTER

OTHERS



## TOOL POINT GAUGE



TP-50

### DIMENSIONS

Units: mm

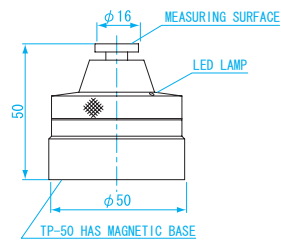

USE • High accuracy position detection

### FEATURES

- Alloy tool steel
- Zero point with light sensor(electr)
- Zero point setting (NC lathe, Machining Center)

Order No.	Model No.	Nominal Size (mm)	Accuracy (mm)	Repeatability	Measuring Force
013205	TP-50	50	$50^{+0.005}_0$	$\pm 1 \mu\text{m}$	2.5N
013206	TP-50M	50	$50^{+0.005}_0$	$\pm 1 \mu\text{m}$	2.5N

Stroke	Magnetic Force	Weight
3mm	—	300g
3mm	29N	300g

## TOOL POINT GAUGE WITH DIAL GAUGE



### DIMENSIONS

Units: mm

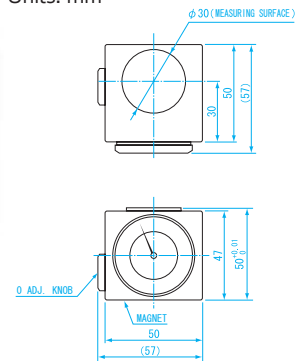

USE • Position detection with dial gauge

### FEATURES

- Measuring surface: SKD11
- Body : S45C
- Easy zero setting with dial gauge
- With magnet on the bottom surface

Order No.	Model No.	Nominal Size (mm)	Accuracy (mm)	Repeatability (m)	Measuring Force less than	Dial gauge Graduation (mm)
013207	DTP-50M	50	$50^{+0.01}_0$	$\pm 10 \mu\text{m}$	5N	0.01

Stroke	Magnetic Force	Weight
2mm	100N	840g

## POINT MASTER WITH CARBIDE TIP



K2-32

K2-20

### DIMENSIONS

Units: mm

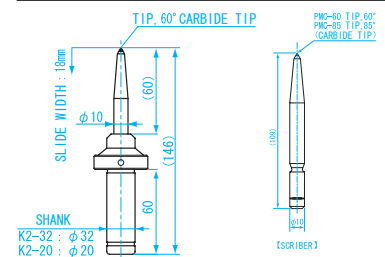

USE • Marking for milling operation

### FEATURES

- Body · Scriber: Carbon tool steel
- Tip: Carbide tip
- High accuracy marking operation can be performed
- 60° carbide tip comes with standard

### SPECIFICATION

- Slide width: 18mm
- Spring strength: 3.5-4N (for 10mm spring compression)
- Concentricity: 0.02mm
- Steel ball diameter: 5mm

Order No.	Model No.	Point Angle	Length (mm)	Scriber Diameter (mm)	Weight
013420	K2-32	60°	146	10	510g
013425	K2-20	60°	146	10	280g
013421	PMC-60(Scriber)	60°	109	10	58g
013422	PMC-85(Scriber)	85°	109	10	54g

## SPEED CONTROLLER

### DIMENSIONS

Units: mm

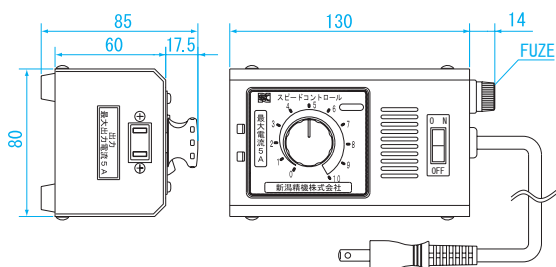

### FEATURES

- Useful for: Electric drills, Hand grinders, Belt sanders, Jig-saws, Disc grinders, Drivers, Heating equipment, Soldering irons & Incandescent lights
- Body: Steel
- Energy saving model reduces power and eliminates wasteful energy use
- With power switch
- Noise (interference) protection (TV, radio etc.)
- Control for reduced speed

### SPECIFICATIONS

- Single phase
- Rated voltage: AC100V
- Rated frequency: 50-60Hz
- Operating temperature range: 0-45°C
- Control: Triac phase control
- Load current: 5A

Comparison of level control settings



Level set to 5

Level set to 10

Order No.	Model No.	Weight
011305	SP-105	600g

## SPEED CONTROLLER

### DIMENSIONS

Units: mm

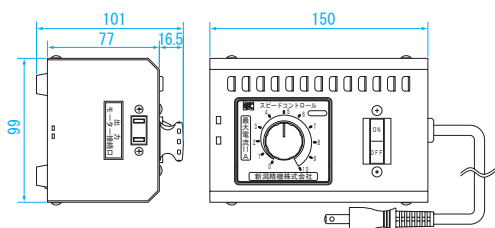

### FEATURES

- Control speed of power tools(single phase commutator motors) and dimming of incandescent lights
- Body: Steel
- Energy saving model reduces power and eliminates wasteful energy use
- With power switch
- Circuit protection: circuit breaker
- Control for reduced speed

### SPECIFICATIONS

- Single phase
- Rated voltage: AC100V
- Rated frequency: 50-60Hz
- Operating temperature range: 0 ~ 45°C
- Control: Triac phase control
- Load current: 11A

Order No.	Model No.	Weight
011311	SP-110	1kg

SURVEYORS WHEEL

COUNTER

DRILL CASE

TOOLING

ELECTRIC TOOLS

WORKING TOOLS

SUCTION LIFTER

OTHERS

## MINI PUMP

Update on classic tool! Hand drill becomes a mini pump with easy installation onto drill chuck. Now with hex shank for use on standard drill or on driver.



Attached to hand drill Easily lifts water to 2nd floor

**USE** • Water supply and drainage of waste water

**MATERIAL**

- Main body: Plastic
- Rotor: Oil-resistant rubber

**FEATURES**

- Corrosion resistant pump is self contained. Operated by a standard electric hand drill

**SPECIFICATIONS**

- Hose diameter: 16mm
- Max water rise: 12m
- Pumping capacity: 10 ~ 12L/min
- Operating speed: 1600min<sup>-1</sup>
- Shaft diameter: 6.35mm
- Accessories: hose band 2pc

**DIMENSIONS**

Units: mm

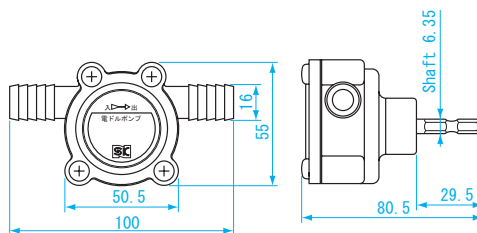

Order No.	Model No.	Drive shaft	Weight
011771	RDP-01	1/4" hex shaft (6.35mm)	160g

## T-HANDLE RATCHET TAP WRENCH



RTH-M

**DIMENSIONS**

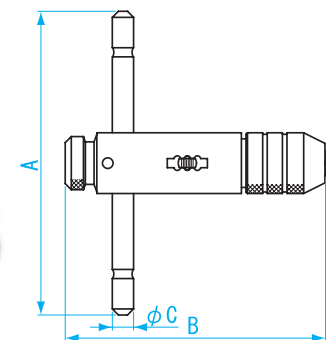

Units: mm

Model No.	A	B	C
RTH-M	100	85	7
RTH-L	120	110	8

**USE** • Tapping

**FEATURES**

- Body: Carbon tool steel
- Chuck: Sintered metal
- Sliding T-shaped handle
- Can work with one hand
- Tapping easily in narrow spaces
- Three switch position (left, right and fixed)

Order No.	Model No.	Size	Tap Range	Weight
013002	RTH-M	M	M3 ~ M8	200g
013003	RTH-L	L	M8 ~ M12	330g

## TAP WRENCH



TRS-1

**DIMENSIONS**

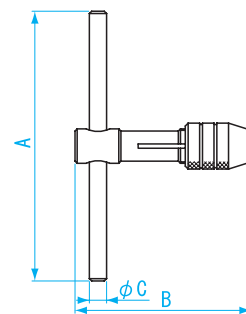

Units: mm

Model No.	A	B	C
TRS-1	94	60	6
TRS-2	103	74	6
TRS-3	124	90	8

**USE** • Tapping

**FEATURES**

- Carbon tool steel
- Sliding T-shaped handle
- Can work with one hand
- Tapping easily in narrow spaces

Order No.	Model No.	Tap Range	Weight
012995	TRS-1	M3 ~ M6	90g
012996	TRS-2	M4 ~ M10	130g
012997	TRS-3	M8 ~ M12	210g

SURVEYORS WHEEL  
COUNTER  
DRILL CASE  
TOOLING  
ELECTRIC TOOLS  
WORKING TOOLS  
SUCTION LIFTER

OTHERS

# FOLDING HEX WRENCH SET



## DIMENSIONS

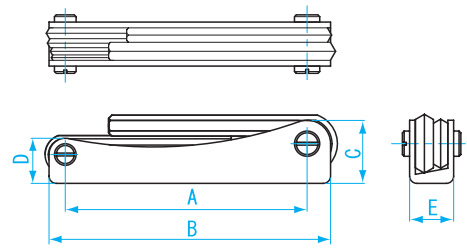

Units: mm

Model No.	A	B	C	D	E
HKS-1	67	78	17.5	12.5	12
HKS-2	86	105	28	21	20
HKS-02	86	105	28	21	20
HKS-B2	86	105	28	21	20

**USE** • For use on Hex head bolt and screws

### FEATURES

- Chrome molybdenum steel
- Hardness: HV510 ~ 600
- Operates at oblique angle (Max angle 30°)

Order No.	Model No.	Type	Size						Weight
			1.5	2	2.5	3	4	5	
013101	HKS-1	mm	1.5	2	2.5	3	4	5	80g
013102	HKS-2	mm	2.5	3	4	5	6	8	230g
013120	HKS-02	inch	3/32	1/8	5/32	3/16	1/4	5/16	240g
013130	HKS-B2	mm (ball point)	2.5	3	4	5	6	8	230g

# SUCTION LIFTER



**USE** • For lifting and transporting material with no handle, such as metal sheet and glass.

### FEATURES

- Strong suction with one lever operation
- Easy to grasp handle for lifting and carrying cumbersome objects.

Order No.	Model No.	Suction Face (mm)	Maximum load capacity	Weight
160200	SL-A20	φ 123	20kg	340g
160201	SL-A30	φ 123	30kg	480g
160202	SL-B25	φ 115	25kg	820g
160203	SL-W40	φ 123 × 2	Horizontal Direction 40kg/ Vertical Direction 80kg	1230g