

GAP CALIPER (THREE BALL POINTS BASE)

Quick tool for easy gap/step measurement.
Well-requested 3 ball points (spherical points) base added to the collection.

Rust prevention ▶
Zerust Film for Steel

P380

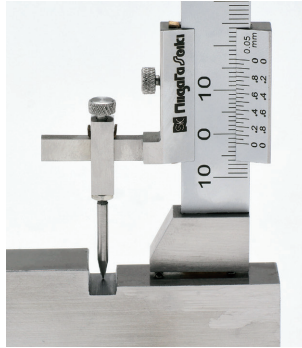

The gauge point is adjustable



Three ball points (spherical points) base

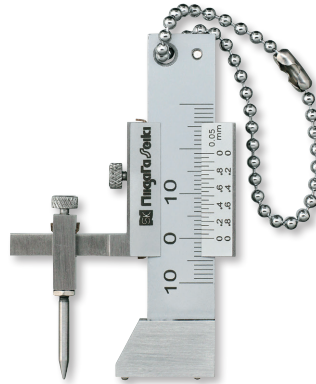

● DIMENSIONS

Units: mm

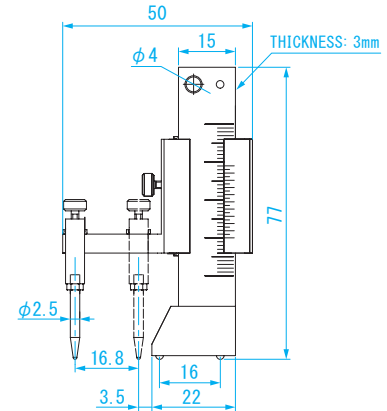

USE

- Step depth measurement

MATERIAL

- Stainless steel

FEATURES

- Bottom base in cavity structure
- Ball chain attached

Order No.	Model No.	Measuring Range (mm)	Resolution (mm)	Accuracy (mm)	Probe Operation Range (mm)	Base Shape	Probe	Arm	Weight
152332	GVG-3R-S1	± 10mm	0.05	± 0.05	16.8	Three ball points (spherical points)	Stainless steel Tip SR0.5mm	Straight	75g