

Reference Gages

Length Standards Brought to You by Mitutoyo

Precision Levels SERIES 960

- High-precision longitudinal and transverse vials make it possible to check or level surfaces.

SPECIFICATIONS

Order No.	Sensitivity (mm/m)	Dimensions (WxDxH) (mm)
960-603	0.02	200x44x38.2
960-703	0.02	200x44x200



960-603

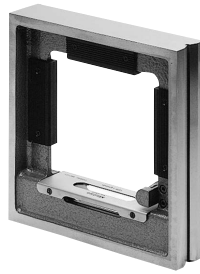

960-703

Technical Data

- Accuracy of graduations: ± 0.7 DIV (960-603), ± 0.3 DIV (960-703)

Bench Centers SERIES 967

FEATURES

- Used with a dial test indicator (optional), these Bench Centers provide precision measurement of concentricity on cylindrical workpieces.
- With an indicator clamp. (Holding stem diameter: 8 mm)

Dimensions

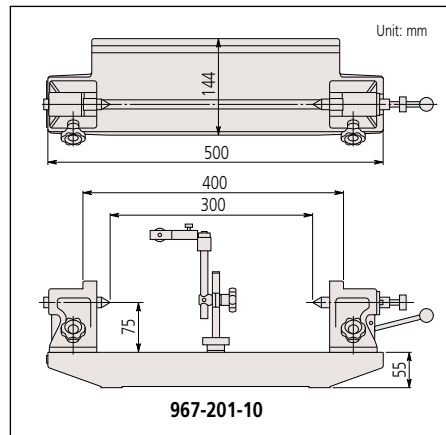

967-201-10

Technical Data

- Maximum workpiece length: 300 mm
- Maximum workpiece dia.: 150 mm
- Mass: 13 kg

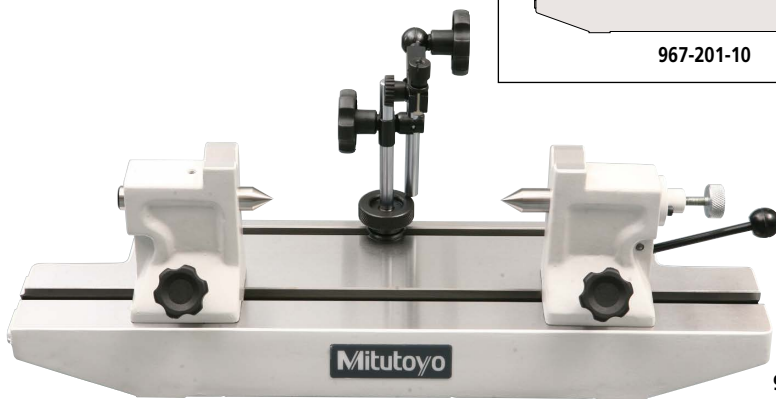

967-201-10