

Calipers

An industry standard measuring tool

ABSOLUTE Coolant Proof Carbon Fiber Caliper SERIES 552 - with Long Jaws

- IP66 Absolute Digital Caliper (Refer to page D-6 for details on the Absolute function.)
- Lightweight Digimatic Calipers that employ CFRP (Carbon Fiber Reinforced Plastics) in the beam.
- Allows integration into statistical process control and measurement systems for models with measurement data output connector. (Refer to page A-3.)



552-151-10

SPECIFICATIONS

Metric			Inch / Metric		
Order No.	Range (mm)*	Accuracy (mm)	Order No.	Range (in)*	Accuracy (in)
552-150-10	0 - 450 (20.1 - 470)	±0.06	552-160-10	0 - 18 (0.504 - 18.5)	±0.0025
552-151-10	0 - 600 (20.1 - 620)		552-161-10	0 - 24 (0.504 - 24.5)	
552-152-10	0 - 1000 (20.1 - 1020)	±0.07	552-162-10	0 - 40 (1.004 - 40.5)	±0.003
552-153-10	0 - 1500 (20.1 - 1520)	±0.11	552-163-10	0 - 60 (1.004 - 60.5)	±0.0045
552-154-10	0 - 2000 (20.1 - 2020)	±0.14	552-164-10	0 - 80 (1.004 - 80.5)	±0.0055

* () : Dimension in inside measurement

Note: A constant-force mechanism is used in the finger rest; however, this is only an auxiliary mechanism to avoid measurement error caused by excessive measuring force. To measure with good accuracy, use the minimum necessary measuring force for the caliper measuring faces to make sufficient contact with the workpiece. Refer to page D-40 for details.

DIMENSIONS

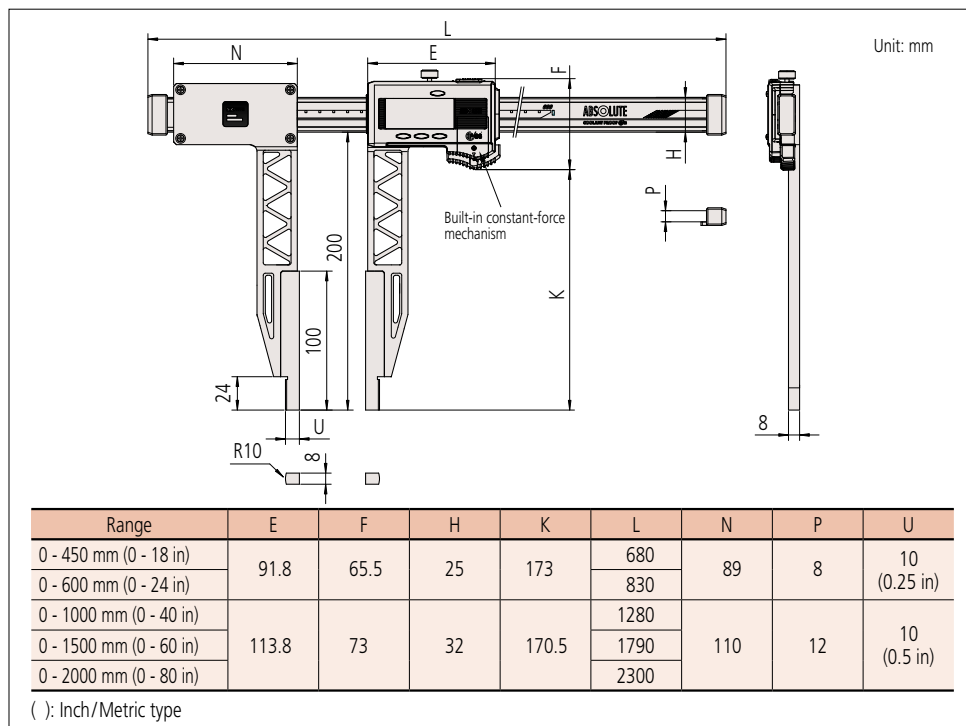

MeasurLink ENABLED
Data Management Software by Mitutoyo

Products equipped with the measurement data output function can be connected to the measurement data network system MeasurLink (refer to page A-5 for details).

ABSOLUTE™

IP66



www.tuv.com
ID 000022582

Technical Data

- Repeatability: 0.01 mm
- Accuracy: Refer to the list of specifications. (excluding quantizing error)
- Resolution: 0.01 mm or 0.0005 in/0.01 mm
- Material of jaws: Stainless Steel Hardened
- Max. response speed: Unlimited
- Battery: SR44 (1 pc), **938882**, for initial operational checks (standard accessory)
- Battery life: Approx. 5,000 hours in continuous use
- Dust/Water protection level: IP66 (IEC 60529)*
- Standard accessory: Jaw clamps (2 pcs.), 05GZA033
- * Rustproofing shall be applied after use if caliper was in contact with coolant.

Functions

- Zero-setting
- Data hold
- Offsetting
- Presetting
- Data output
- Low-power and low-voltage alert
- Counting value composition error
- Automatic power on/off, inch/mm reading (inch/mm models)

Optional Accessories

For details, refer to page A-27.

- Connecting cables for **IT / DP / MUX**
- 05CZA624**: SPC cable with data button (1 m)
- 05CZA625**: SPC cable with data button (2 m)



- USB Input Tool Direct
- 06AFM380A**: SPC cable for **USB-ITN-A** (2 m)
- Connecting cables for **U-WAVE-T**
- 02AZD790A**: SPC cable with data button (160 mm)
- 02AZE140A**: SPC cable for foot switch